



Leadscrew Type Pocket Door Operator



Product Background

The leadscrew type electric operator for passenger pocket doors is specifically designed for use in rapid operation, high passenger density environments such as mass transit metro vehicles. The door operating mechanism is suited to mount above the doorway opening and DOORspec can tailor the layout of the operator to adapt to any vehicle cantrail layout.

The door operating mechanism makes use of an electric drive motor connected to a “lubrication free” double helix leadscrew that drives both door panels through left and right hand screw nuts. A door locking system, activated by the door movement and released by an ECU controlled solenoid, is an integral part of the operator and is independent from the drive system. The door guidance system is comprised of an anodized “C” track and molded polyurethane rollers and is an integral part of the operator unit

The design provides the following features:

- Single or double panel operation
- Obstacle detection
- Internal and external Emergency release
- Crew access switches
- Fault Diagnostics
- Communications Link with TMS
- Audible and visual door close warning
- Monitoring and diagnostics on PC

Specifications

Operation:	Electric Motor Drive
Control:	Electronic Control Unit (ECU)
Input Voltage:	24, 36, 48 and 110 Vdc
Power Consumption:	60 W (Run) / 220 W (Peak)
Opening Time:	Adjustable from 2.0 sec. and up
Closing Time:	Adjustable from 3.0 sec. and up
Clear Opening:	Up to 1500 mm (Width)
System Weight:	30 to 40 Kg

Construction

The door operator complete with ECU is supplied fully assembled and factory tested ready for installation above the doorway.

Drive Motor:	“Step free” permanent magnet with position encoder
Microprocessor:	Multi-Layer PCB of the latest surface mounting Technology
Guidance	Hard anodized Upper “C” track and molded polyurethane roller system.
Drive System:	Lubrication free LeadScrew System
Locking System:	Activated by Door Movement and Released by Solenoid
Obstacle Detection:	Encoder counts and ECU Current Monitoring system
Wiring:	Low smoke, low halogen cable for all wiring within the door operator
Interlocks:	Switches for Closed and Locked Indication

Tested To

Shock and Vibration	RIA 20
Climate Conditions	RIA 13
EMC	RIA 18
Cycling Endurance	2 million operations

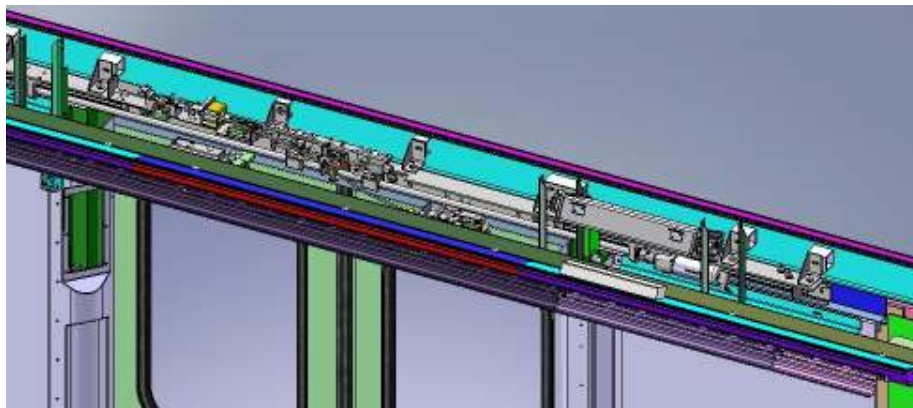
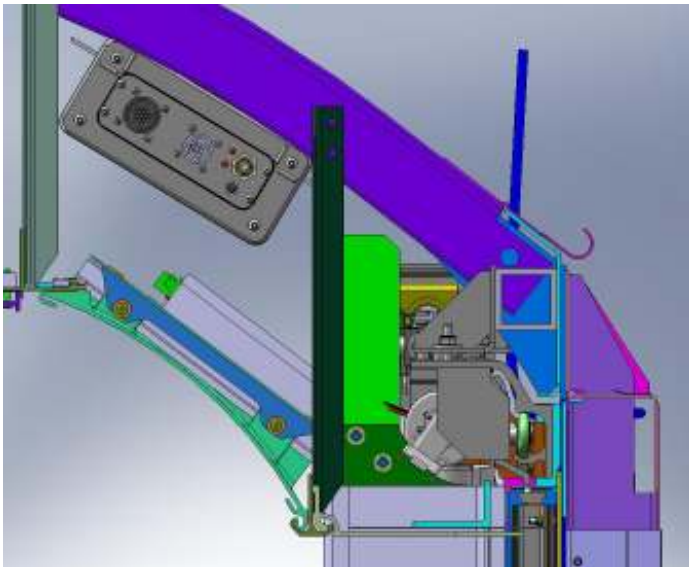
Typical Leadscrew Pocket Door Operator Systems***United States***

DOORspec Solutions Inc.
290 Margaret Street.
Plattsburgh, NY
12901
Tel: 518 324-7177
Fax: 518 324-4490

Canada

Solutions DOORspec Inc.
1225, Industrielle
La Prairie, Qc.
J5R 2E4
Tel: 450 444-6994
Fax: 450 444-9347

Web Site

www.door-spec.com

E-Mail Address

Info@door-spec.com